

MODULE 30m²

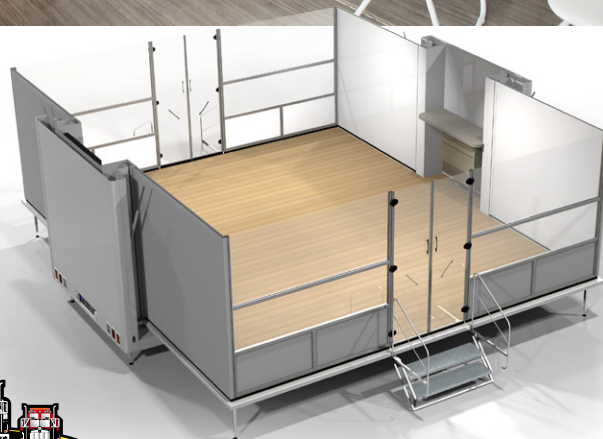

Cette remorque climatisée d'une surface de 30 m² est destinée à la promotion. Elle permet de nombreuses possibilités d'aménagement et de décoration grâce à d'importantes surfaces de marquage. Tractée par un fourgon, celui-ci peut servir de stockage.



MODULE 30 m²

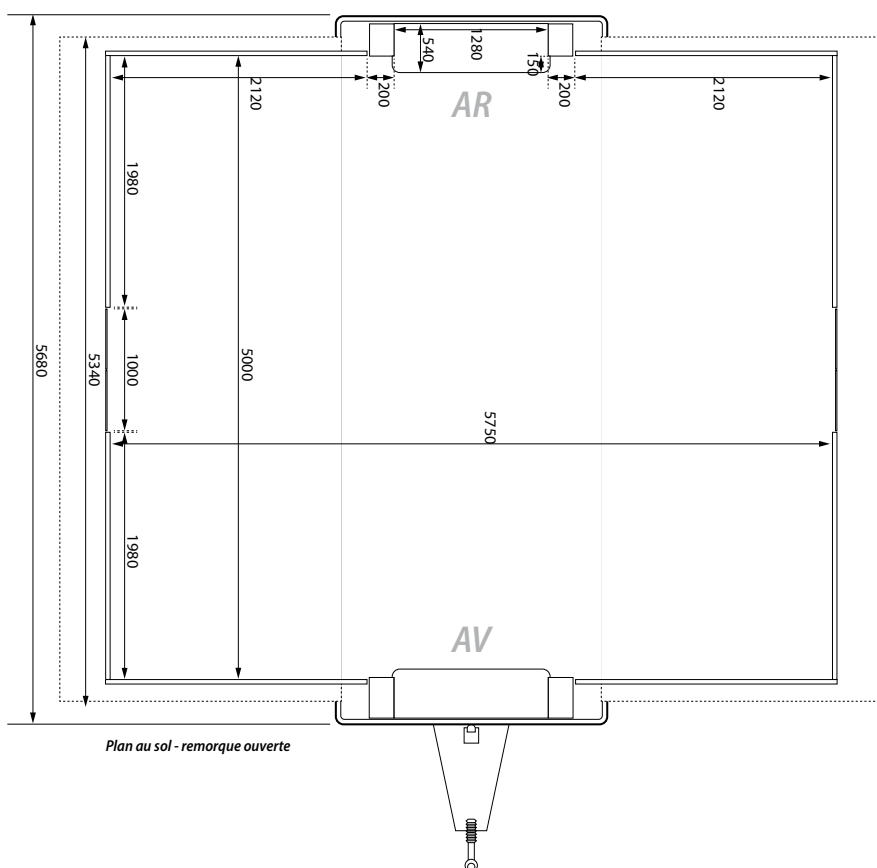
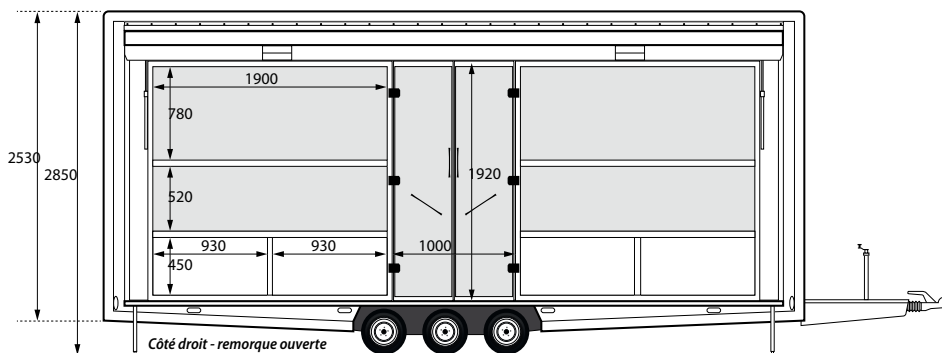
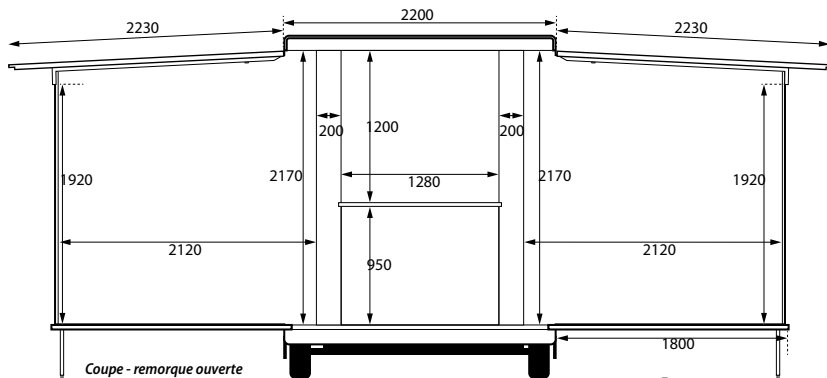
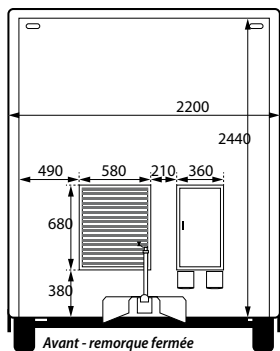
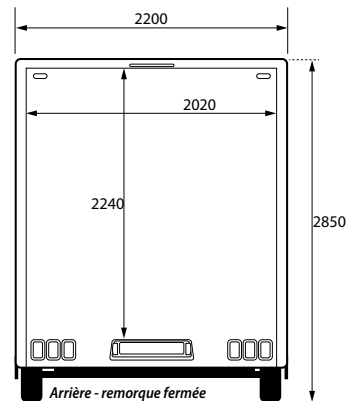
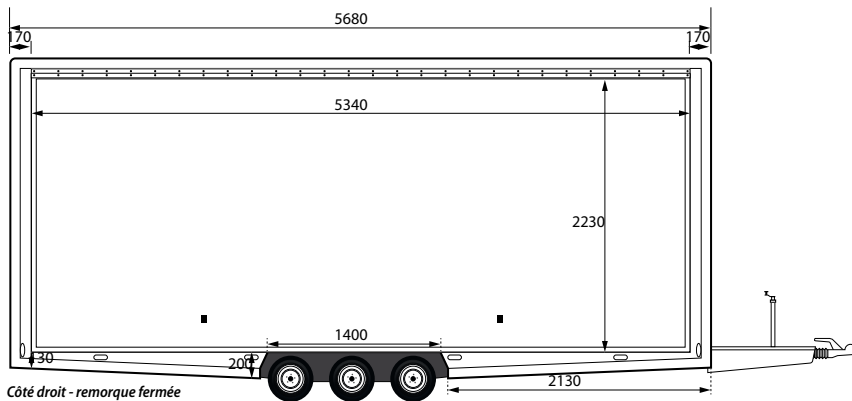

FICHE TECHNIQUE

VÉHICULE : MODULE 30 m²

DIMENSIONS :

Longueur : 5,68 m (+ timon : 1,50 m)
 Largeur fermée : 2,20 m
 Largeur ouverte : 6,70 m
 Hauteur hors tout : 2,85 m

POIDS À VIDE : 2 T

CHARGE UTILE : 500 kg